

GLOBO

LIGHTING

68278-24

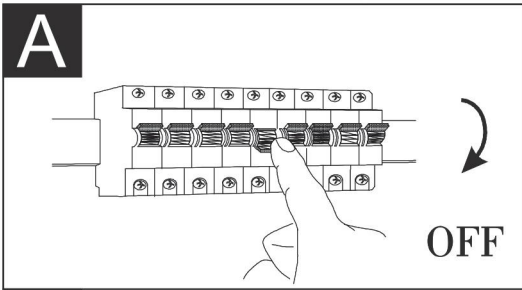

B

LED MAX 24W 36V
220-240V~ 50/60Hz

Frequency Bandwidth	Maximal radiation transmitting power
2402-2426MHz	6dBm

dimmable

4500K 3 6500K
LIGHT STEPS
2700K

incl.

2700K - 6500K

many steps

night light

colour fixing

memory function

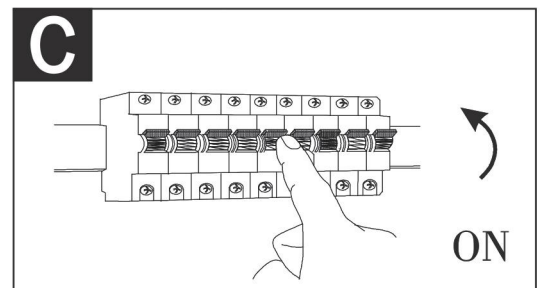
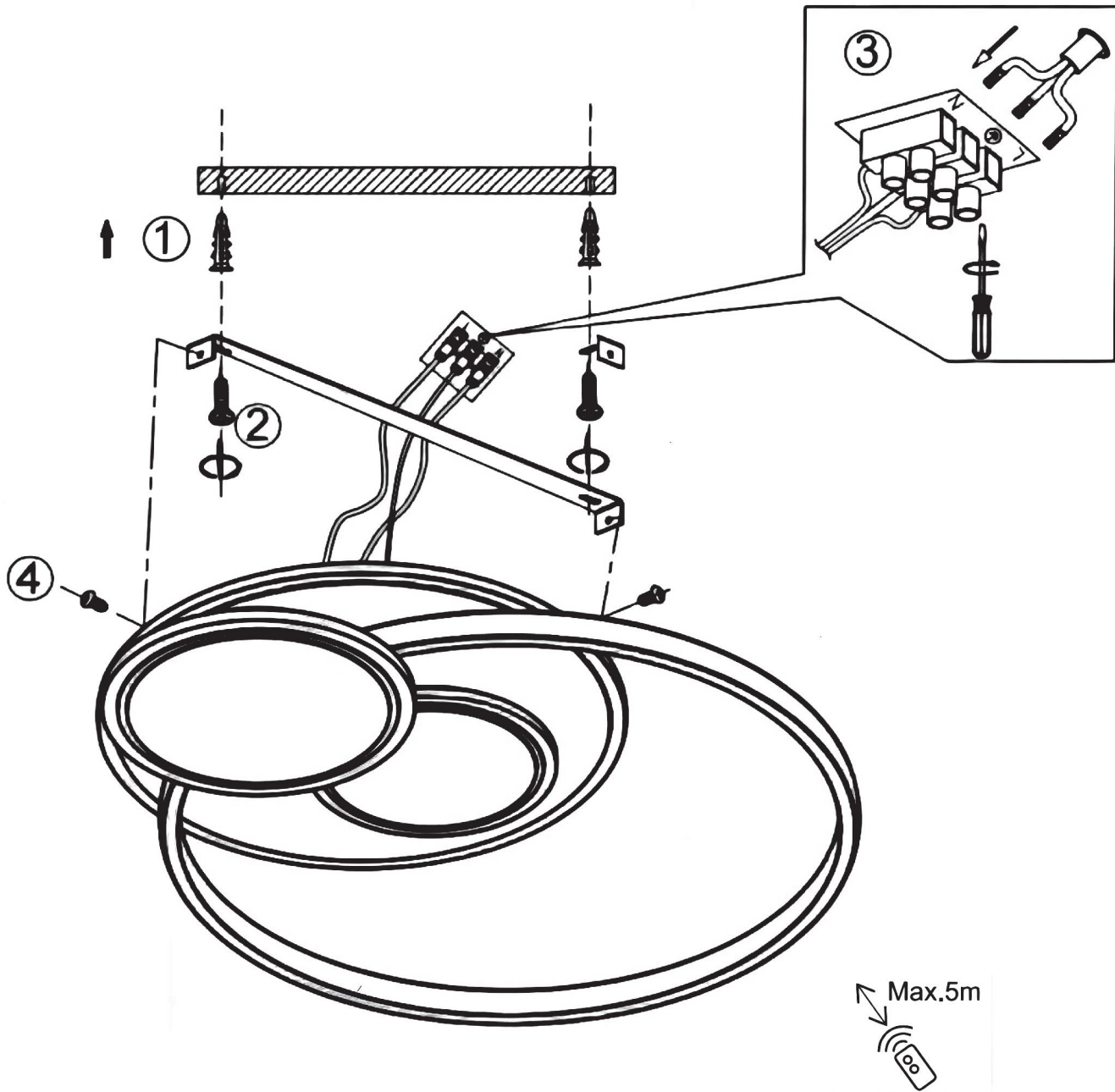

GLOBO Handels GmbH
Gewerbestr. 3
A-9184 Sankt Peter
AUSTRIA
www.globo-lighting.com
office@globo-lighting.com

Reset remote control

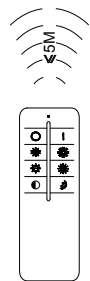
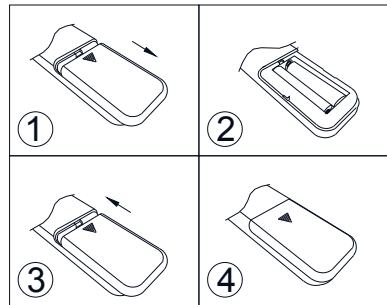
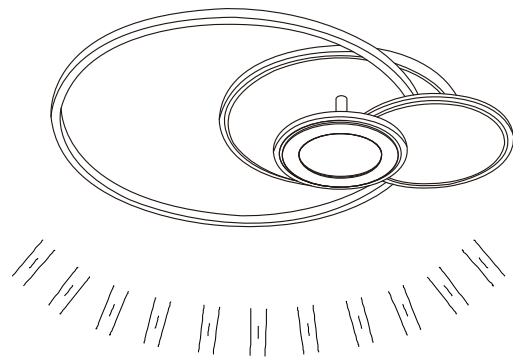
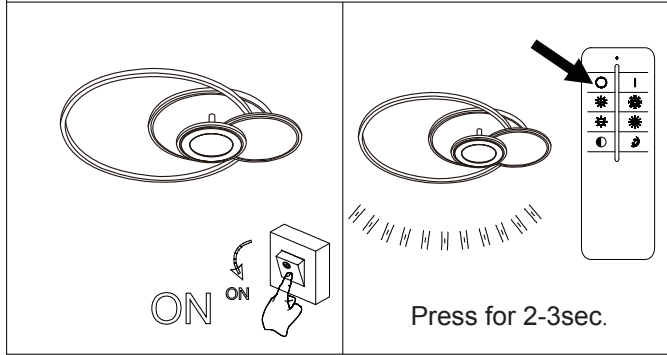

BATTERY DATA

2x AAA battery* incl.

*Manufacturer: Zhongshan Chaoyang Electronics Co., Ltd.
Address: 1/F, workshop 2, No. 7 Damei Road, Gangkou Town,
Zhongshan City
Model: R03 AAA 1.5V

SAFETY INSTRUCTIONS



Wall switch

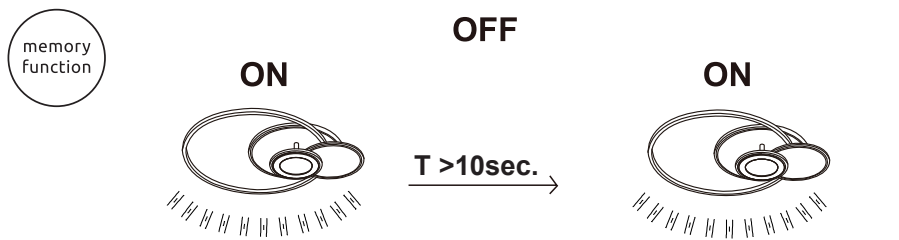
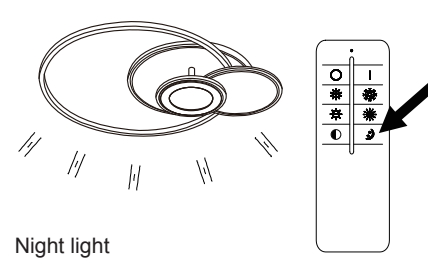
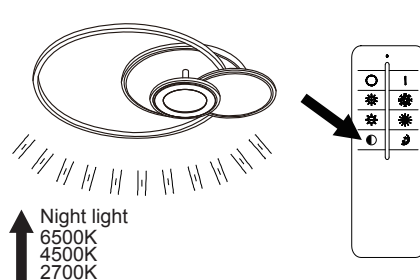
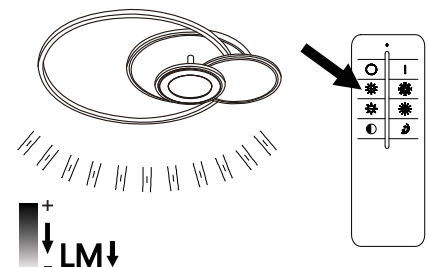
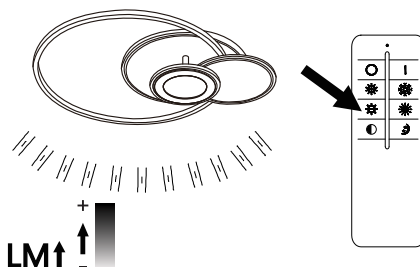
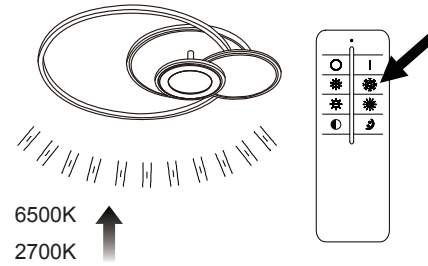
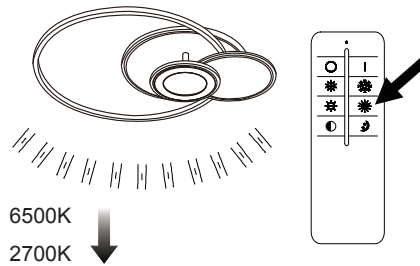
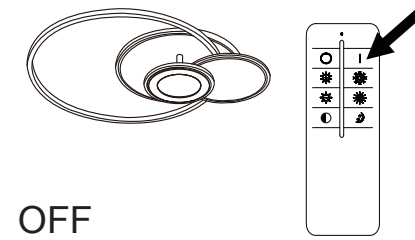
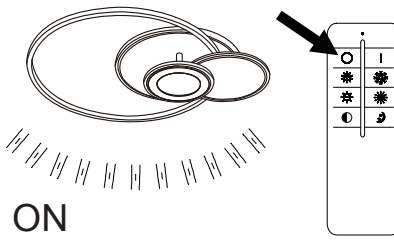
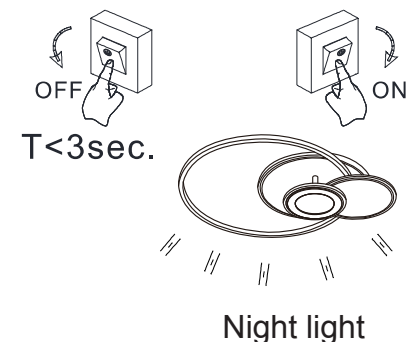
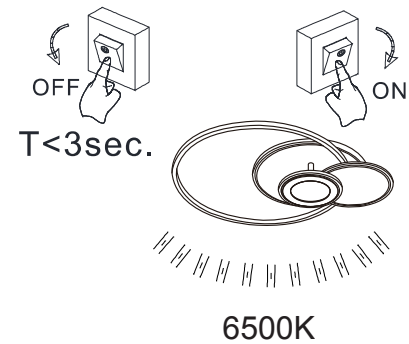
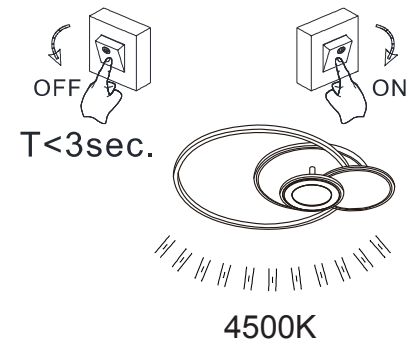
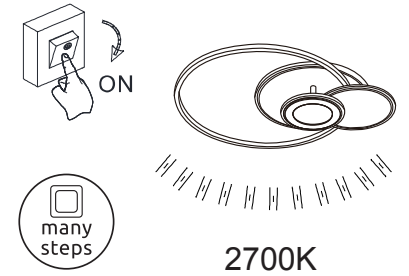

Lichtquelle/Light source:

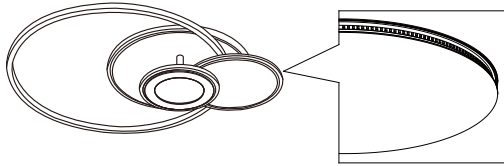

DEU:

Lichtquelle:

Die Lichtquelle ist nicht tauschbar, weil sie konstruktionsbedingt fest mit dem umgebenden Produkt verbunden ist. Dieses Produkt enthält eine Lichtquelle der Energieeffizienzklasse <D>.

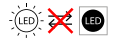
 Die LED - Lichtquelle ist nicht austauschbar.

 Das Betriebsgerät kann nur durch einen Fachmann ausgetauscht werden.

GBR:

Light source:

The light source is not interchangeable because it is determined by the surrounding product design. This product contains a light source of energy efficiency class <D>.

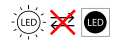
 The LED - light source cannot be replaced.

 The control gear can be replaced by a professional.

BIH & HR:

Izvor svjetla :

Izvor svjetla nije zamjenjiv , jer je konstrukcijski pričvršćen na proizvod . Ovaj proizvod sadržava izvor svjetlosti klase energetske učinkovitosti <D>.

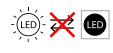
 LED – izvor svjetla nije moguće zamjeniti

 Pogonski uređaj smije zamjeniti samo stručna osoba.

BG:

Източник на светлина:

Източникът на светлина не може да се подменя, тъй като поради конструкцията си е трайно фиксиран към заобикалящия го продукт.

Този продукт включва светлинен източник с клас на енергийна ефективност <D>.

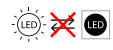
 LED източникът на светлина не може да се подменя.

 Устройството за управление може да се подменя само от специалист.

CZ:

Zdroj světla:

Světelný zdroj není možné vyměnit, protože je díky své konstrukci pevně spojený s produktem. Tento výrobek obsahuje světelný zdroj s třídou energetické účinnosti <D>.

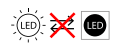
 Světelný zdroj není vyměnitelný.

 Výměna předřadníku pouze odborníkem.

DK:

Lyskilde:

Lyskilden kan ikke udskiftes, fordi den er fast forbundet med det omgivende produkt. Dette produkt indeholder en lyskilde i energieffektivitetsklasse < D>.

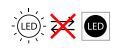
 LED- lyskilden kan ikke udskiftes.

 Driftsenheden kan kun skiftes af en fagperson.

ET:

Valgusallikas:

Valgusallikas ei ole välja vahetatav, sest ta on tootega ehituslikult kindlalt seotud. Toode sisaldab energiatõhususe klassi <D> valgusallikat.

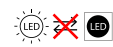
 LED - valgusallikat ei saa asendada.

 Juhtseadmed võib asendada professionaalne.

FI:

Valonlähde:

Valonlähdettä ei voi vaihtaa uuteen, sillä se on rakenteellisesti yhdistetty ympäröivään tuotteeseen. Tämä tuote sisältää valonlähteen, jonka energiatehokkuusluokka on <D>.

 LED-valonlähdettä ei voi vaihtaa uuteen.

 Vain ammattihenkilö voi vaihtaa liitäntälaitteen.

FR:

Source lumineuse:

La source lumineuse n'est pas remplaçable car elle est, de par la construction du produit, liée de façon permanente à celui-ci.

Ce produit contient une source lumineuse de classe d'efficacité énergétique <D>.

 La source lumineuse LED n'est pas remplaçable.

 L'unité de contrôle ne peut être remplacée que par un spécialiste.

GR:

Φωτεινή πηγή:

Η φωτεινή πηγή δεν μπορεί να αντικατασταθεί, επειδή είναι για κατασκευαστικούς λόγους σταθερά συνδεδεμένη με το προϊόν που την περιβάλλει.

Το προϊόν αυτό περιέχει φωτεινή πηγή της τάξης ενεργειακής απόδοσης <D>.

 Η φωτεινή πηγή LED δεν αντικαθίσταται .

 Η λειτουργική συσκευή μπορεί να αντικατασταθεί μόνο από έναν ειδικό.

HU:

Fényforrás:

A fényforrás nem cserélhető, mert felépítése miatt szilárdan csatlakozik a termékhez. Ez a termék egy <D> energiahatékonysági osztályú fényforrást tartalmaz.

 A fényforrás nem cserélhető

 Az előtétet csak szakértők cserélhetik ki.

IS:

Ljósgefafi:

Ljósgefafinn er ekki útskiptanlegur vegna þess að hann er háður umliggjandi hönnun vörunnar.

Varan inniheldur ljósgefafa í orkuflokki <D>.

 Ekki er hægt að skipta um LED-ljósgefafann.

 Aðeins fagmenn mega skipta um stjórnbúnaðinn.

IT:

Sorgente luminosa:

La sorgente luminosa non è intercambiabile perché è saldamente collegata al prodotto per via del suo design. Questo prodotto contiene una sorgente luminosa di classe di efficienza energetica <D>.

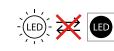
 La sorgente luminosa a LED non può essere sostituita.

 L'alimentatore può essere sostituito solo da personale specializzato.

LV:

Gaismas avots:

Gaismas avotu nevar nomainīt, jo tas konstrukcijā ir cieši savienots ar izstrādājuma apkārtējo daļu. Šis ražojums satur gaismas avotu, kura energoefektivitātes klase ir <D>.

 LED apgaismes līdzekļi nevar nomainīt.

 Vadības ierīci var nomainīt speciālists.

LT:

Šviesos šaltinis:

Šis šviesos šaltinis yra nekeičiamas, nes jis prijungtas prie gaminio pagal jo konstrukciją.

Šiame gaminyje yra šviesos šaltinis, kurio energijos vartojimo efektyvumo klasė <D>.

 LED šviesos šaltinis yra nekeičiamas.

 Valdymo įtaisą gali pakeisti tik tam kvalifikuotas specialistas.

NL:**Lichtbron:**

De lichtbron kan niet worden vervangen, omdat deze vanwege de constructie vast met het product eromheen verbonden is.

Dit product bevat een lichtbron van energie-efficiëntieklasse <D>.

 De LED-lichtbron kan niet worden vervangen.

 Het apparaat kan alleen door een vakman worden vervangen.

NO:**Lyskilde:**

Lyskilden kan ikke byttes fordi den sitter fast i produktet.

Dette produktet inneholder en lyskilde i energiklasse <D>.

 LED-lyspæren kan ikke byttes.

 Driverenheten kan kun byttes av fagmann.

PL:**Źródło światła:**

Źródła światła nie można wymienić, ponieważ jest zintegrowane z produktem ze względu na swoją konstrukcję.

Ten produkt zawiera źródło światła o klasie efektywności energetycznej <D>.

 LED - źródło światła nie może być wymienione.

 Urządzenie sterujące może zostać wymienione przez specjalistę.

PT:**Fonte de Luz:**

A fonte de luz não é substituível porque devido às suas características construtivas está fixada de forma permanente ao produto circundante.

Este produto contém uma fonte de luz da classe de eficiência energética <D>.

 Lâmpada não substituível.

 Substituição do equipamento de controlo por um profissional.

RO:**Sursa de lumina:**

Sursa de lumina nu este inlocuibilă ea fiind parte constructivă a produsului

Acest produs conține o sursă de lumină cu clasa de eficiență energetică <D>.

 Sursa de lumina nu poate fi înlocuită.

 Driverul poate fi înlocuit doar de către personal specializat.

RUS:**Источник света:**

Источник света не является взаимозаменяемым, поскольку это определяется конструкцией смежного продукта.

Данный продукт содержит источник света класса энергоэффективности <D>.

 Светодиодный источник света не подлежит замене.

 Устройство управления может заменяться только квалифицированным специалистом.

SRB:**Izvor svetlosti:**

Izvor svetlosti nije zamenljiv, jer je zbog svog dizajna čvrsto povezan sa proizvodom koji ga opkružuje.

Ovaj proizvod sadrži izvor svetlosti klase energetske efikasnosti <D>.

 LED izvor svetlosti nije zamenljiv.

 Upravljački uređaj može da zameni samo specijalista.

SK:**Zdroj svetla:**

Svetelný zdroj nie je možné vymeniť, pretože je vďaka svojej konštrukcii pevne spojený s produktom.

Tento výrobok obsahuje svetelný zdroj triedy energetickej účinnosti <D>.

 Svetelný zdroj nie je vymeniteľný.

 Výmena predradníka len odborníkom.

SI:**Izvor svetlobe:**

Vir svetlobe ni zamenljiv, ker je določen z zasnovno izdelka v okolici.

Ta izdelek vsebuje svetlobni vir razreda energijske učinkovitosti <D>.

 Svetlobni vir ni mogoče zamenjati.

 Krmilno napravo lahko zamenja samo strokovno usposobljena oseba.

ES:**Fuente de luz:**

La fuente de luz no es sustituible porque está fija en el producto desde la construcción.

Este producto contiene una fuente luminosa de la clase de eficiencia energética <D>.

 Bombilla no reemplazable.

 Sustitución del aparato por un profesional.

SE:**Ljuskälla:**

Ljuskällan är inte utbytbar, eftersom den på grund av konstruktionen är fast integrerad i den omgivande produkten.

Denna produkt innehåller en ljuskälla med energieffektivitetsklass <D>.

 LED-ljuskällan kan inte bytas ut.

 Driftdonet kan endast bytas ut av en fackman.

TR:**Işık kaynağı:**

Konstrüksiyon gereği çevreleyen ürün ile sabit bir şekilde bağlı olduğu için ışık kaynağı değiştirilemez.

Bu ürün, <D> enerji sınıfından bir ışık kaynağına sahiptir.

 LED ışık kaynağı değiştirilemez.

 İşletme cihazı sadece bir uzman tarafından değiştirilebilir.

UK:**Джерело світла:**

Джерело світла не можна обміняти, оскільки воно міцно пов'язане з навколишнім виробом завдяки своїй конструкції.

Цей виріб містить джерело світла класу енергоефективності <D>.

 джерело світлодіодного світла не можна замінювати.

 лише фахівець може замінювати пристрій керування.