

**B**

touch dimmer

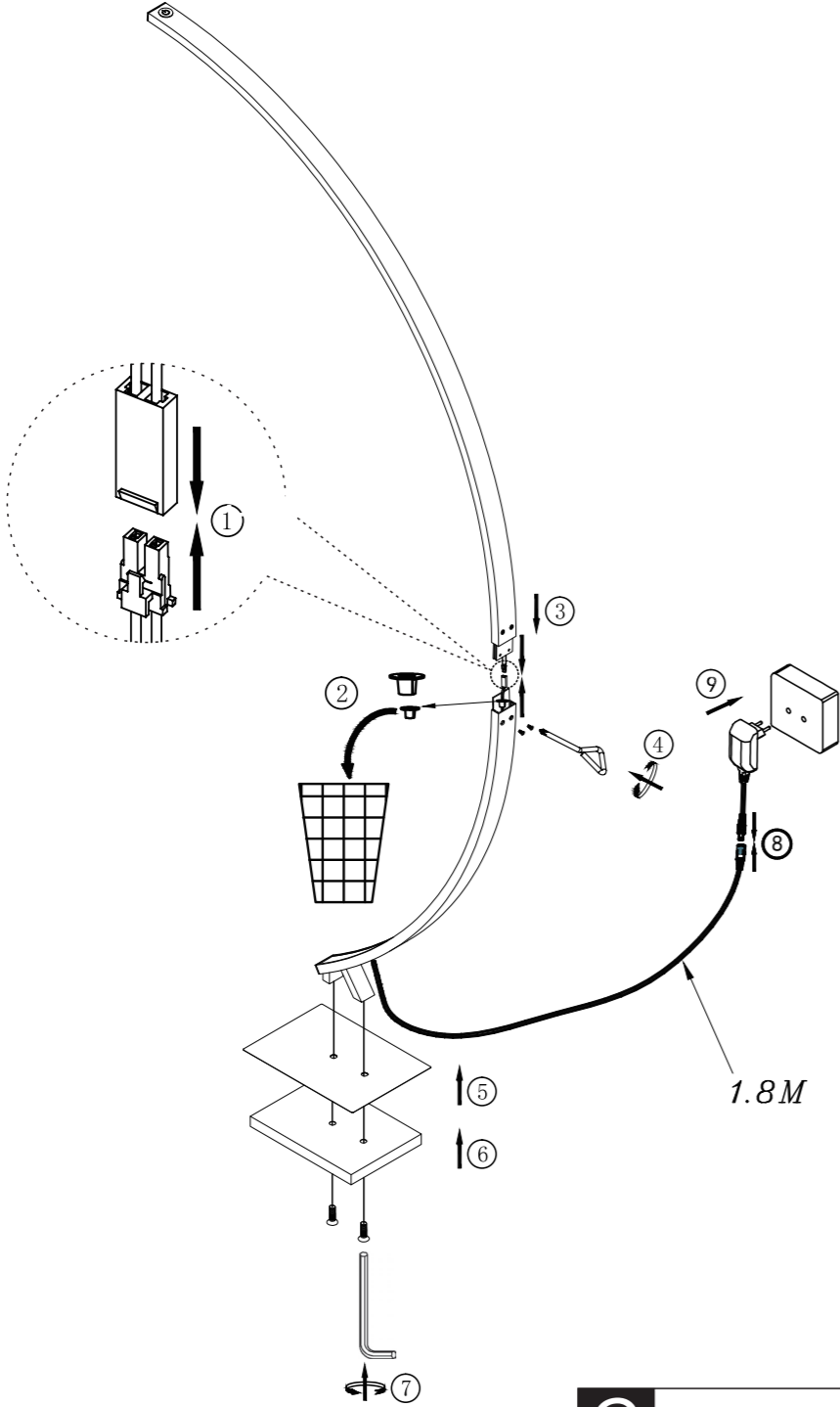

# GLOBO

LIGHTING  
www.globo-lighting.com

67815-24S

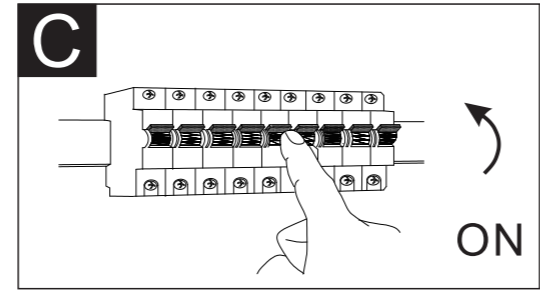

GLOBO Handels GmbH  
Gewerbestr. 3  
A-9184 Sankt Peter AUSTRIA

## Lichtquelle/Light Source:

DEU:  
Lichtquelle:  
Die Lichtquelle ist nicht tauschbar, weil sie konstruktionsbedingt fest mit dem umgebenden Produkt verbunden ist.  
Dieses Produkt enthält eine Lichtquelle der Energieeffizienzklasse <F>.

 Das Betriebsgerät kann durch den Endkunden ausgetauscht werden.

 Die LED - Lichtquelle ist nicht austauschbar.

GBR:  
Light source:  
The light source is not interchangeable because it is determined by the surrounding product design.  
This product contains a light source of energy efficiency class <F>.

 The control gear can be replaced by an end-user.

 The LED - light source cannot be replaced.

BIH:  
Izvor svjetla :  
Izvor svjetla nije zamjenjiv , jer je konstrukcijski pričvršćen na proizvod .  
Ovaj proizvod sadržava izvor svjetlosti klase energetske učinkovitosti <F>.

 Pogonski uređaj može zamjeniti krajnji korisnik .

 LED – izvor svjetla nije moguće zamjeniti.

BG:  
Източник на светлина:  
Източникът на светлина не може да се подменя, тъй като поради конструкцията си е трайно фиксиран към заобикалящия го продукт.Този продукт включва светлинен източник с клас на енергийна ефективност <F>.

 Устройството за управление може да се подменя от крайния клиент.

 LED източникът на светлина не може да се подменя.

CZ:  
Zdroj světla:  
Světelný zdroj není možné vyměnit, protože je díky své konstrukci pevně spojený s produktem.  
Tento výrobek obsahuje světelný zdroj s třídou energetické účinnosti <F>.

 Výměna předřadníku koncovým uživatelem.

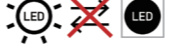
 Světelný zdroj není vyměnitelný.

DK:  
Lyskilde:  
Lyskilden kan ikke udskiftes, fordi den er fast forbundet med det omgivende produkt.  
Dette produkt indeholder en lyskilde i energieffektivitetsklasse <F>.

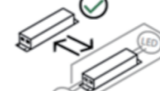
 Driftsenheden kan skiftes af slutkunden.

 LED- lyskilden kan ikke udskiftes.

ET:  
Valgusallikas:  
Valgusallikas ei ole välja vahetatav, sest ta on tootega ehituslikult kindlalt seotud.  
Toode sisaldab energiatõhususe klassi <F> valgusallikat.

 Juhtseadme võib asendada lõppkasutaja.

 LED - valgusallikat ei saa asendada

FI:  
Valonlähde:  
Valonlähdettä ei voi vaihtaa uuteen, sillä se on rakenteellisesti yhdistetty ympäröivään tuotteeseen.  
Tämä tuote sisältää valonlähteen, jonka energiatehokkuusluokka on <F>.

 Loppuasiakas voi vaihtaa liitäntälaitteen.

 LED-valonlähdettä ei voi vaihtaa uuteen.

FR:  
Source lumineuse:  
La source lumineuse n'est pas remplaçable car elle est, de par la construction du produit, liée de façon permanente à celui-ci.  
Ce produit contient une source lumineuse de classe d'efficacité énergétique <F>.

 L'unité de contrôle peut être remplacée par le client

 La source lumineuse LED n'est pas remplaçable.

GR:  
Φωτεινή πηγή:  
Η φωτεινή πηγή δεν μπορεί να αντικατασταθεί, επειδή είναι για κατασκευαστικούς λόγους σταθερά συνδεδεμένη με το προϊόν που την περιβάλλει.  
Το προϊόν αυτό περιέχει φωτεινή πηγή της τάξης ενεργειακής απόδοσης <F>.

 Η φωτεινή πηγή μπορεί να αντικατασταθεί μόνο από έναν ειδικό.

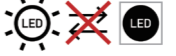
 Η φωτεινή πηγή LED δεν αντικαθίσταται.



# Lichtquelle/Light Source:

HU:  
Fényforrás:  
A fényforrás nem cserélhető, mert felépítése miatt szilárdan csatlakozik a termékhez.  
Ez a termék egy <F> energiahatékonysági osztályú fényforrást tartalmaz.

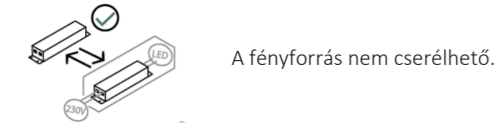

A fényforrás nem cserélhető.

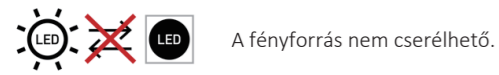

A fényforrás nem cserélhető.

Isländisch/IS:  
Ljósgrafi:  
Ljósgrafi er ekki útskiptanlegur vegna þess að hann er háður umliggjandi hönnun vörunnar.  
Varan inniheldur ljósgrafa í orkuflokki <F>.

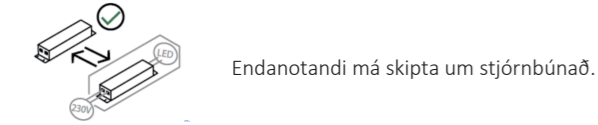

Endanotandi má skipta um stjórnbúnað.

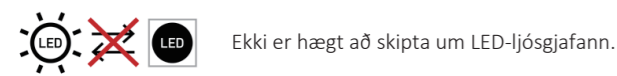

Ekki er hægt að skipta um LED-ljósgrafann.

IT:  
Sorgente luminosa:  
La sorgente luminosa non è intercambiabile perché è saldamente collegata al prodotto per via del suo design.  
Questo prodotto contiene una sorgente luminosa di classe di efficienza energetica <F>.

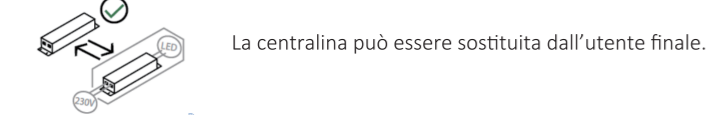

La centralina può essere sostituita dall'utente finale.

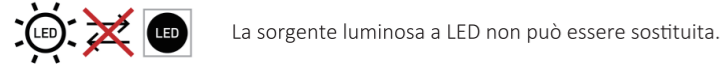

La sorgente luminosa a LED non può essere sostituita.

HR:  
Izvor svjetla:  
Izvor svjetla nije zamjenjiv, jer je konstrukcijski pričvršćen na proizvod.  
Ovaj proizvod sadržava izvor svjetlosti klase energetske učinkovitosti <F>.

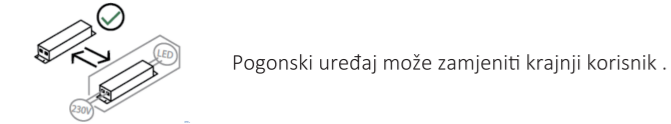

Pogonski uređaj može zamjeniti krajnji korisnik.

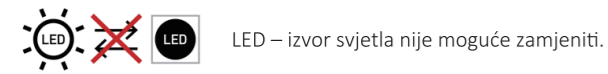

LED – izvor svjetla nije moguće zamjeniti.

LV:  
Gaismas avots:  
Gaismas avotu nevar nomainīt, jo tas konstrukcijā ir cieši savienots ar izstrādājuma apkārtējo daļu.  
Šis ražojums satur gaismas avotu, kura energoefektivitātes klase ir <F>.

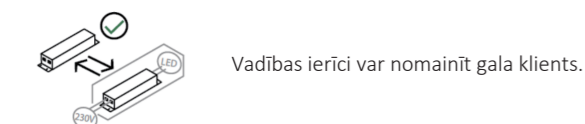

Vadības ierīci var nomainīt gala klients.



LED apgaismes līdzekli nevar nomainīt.

LT:  
Šviesos šaltinis:  
Šis šviesos šaltinis yra nekeičiamas, nes jis prijungtas prie gaminio pagal jo konstrukciją.  
Šiame gaminyje yra šviesos šaltinis, kurio energijos vartojimo efektyvumo klasė <F>.



Valdymo įtaisą gali pakeisti galutinis vartotojas.

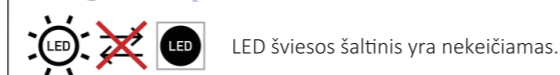

LED šviesos šaltinis yra nekeičiamas.

NL:  
Lichtbron:  
De lichtbron kan niet worden vervangen, omdat deze vanwege de constructie vast met het product eromheen verbonden is.  
Dit product bevat een lichtbron van energie-efficiëntieklasse <F>.

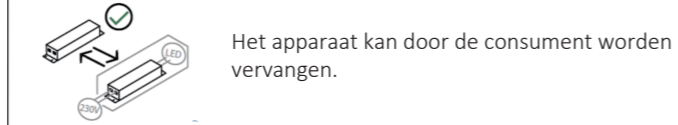

Het apparaat kan door de consument worden vervangen.



De LED-lichtbron kan niet worden vervangen.

Norwegisch/Norwegian / NO:  
Lyskilde:  
Lyskilden kan ikke byttes fordi den sitter fast i produktet.  
Dette produktet inneholder en lyskilde i energiklasse <F>.

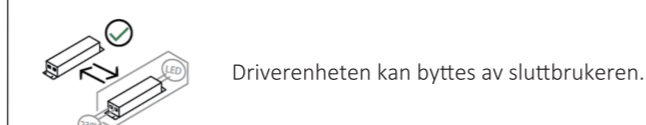

Driverenheten kan byttes av sluttbrukeren.

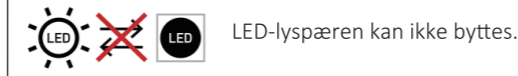

LED-lyspæren kan ikke byttes.

PL:  
Źródło światła:  
Źródła światła nie można wymienić, ponieważ jest zintegrowane z produktem ze względu na swoją konstrukcję.  
Ten produkt zawiera źródło światła o klasie efektywności energetycznej <F>.

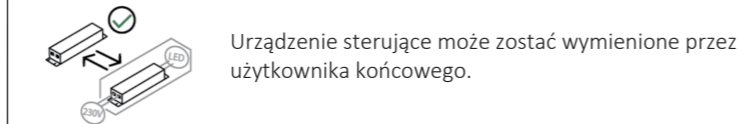

Urządzenie sterujące może zostać wymienione przez użytkownika końcowego.

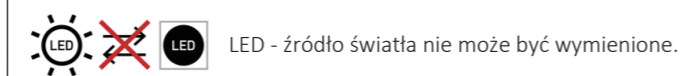

LED - źródło światła nie może być wymienione.

PT:  
Fonte de Luz:  
A fonte de luz não é substituível porque devido às suas características construtivas está fixada de forma permanente ao produto circundante.  
Este produto contém uma fonte de luz da classe de eficiência energética <F>.

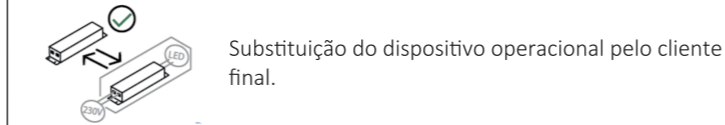

Substituição do dispositivo operacional pelo cliente final.



Lâmpada não substituível.

# Lichtquelle/Light Source:

RO:  
Sursa de lumina:  
Sursa de lumina nu este inlocuibilă ea fiind parte constructivă a produsului.  
Acest produs conține o sursă de lumină cu clasa de eficiență energetică <F>.



Driverul poate fi înlocuit de către utilizator.

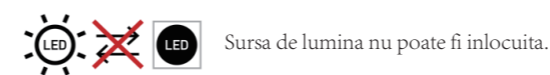

Sursa de lumina nu poate fi înlocuită.

RUS:  
Источник света:  
Источник света не является взаимозаменяемым, поскольку это определяется конструкцией смежного продукта.  
Данный продукт содержит источник света класса энергоэффективности <F>.

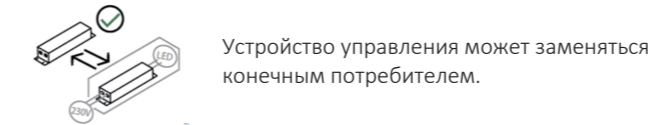

Устройство управления может заменяться конечным потребителем.

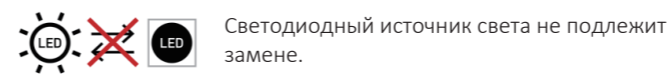

Светодиодный источник света не подлежит замене.

SRB:  
Izvor svetlosti:  
Izvor svetlosti nije zamenljiv, jer je zbog svog dizajna čvrsto povezan sa proizvodom koji ga okružuje.  
Ovaj proizvod sadrži izvor svetlosti klase energetske efikasnosti <F>.

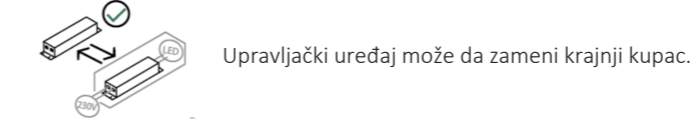

Upravljački uređaj može da zameni krajnji kupac.

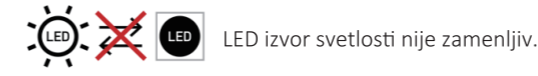

LED izvor svetlosti nije zamenljiv.

SK:  
Zdroj svetla:  
Svetelný zdroj nie je možné vymeniť, pretože je vďaka svojej konštrukcii pevne spojený s produktom.  
Tento výrobok obsahuje svetelný zdroj triedy energetickej účinnosti <F>.

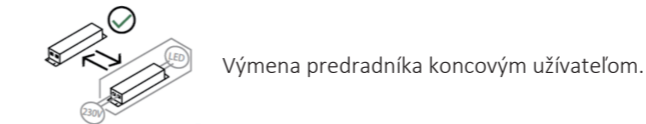

Výmena predradníka koncovým užívateľom.

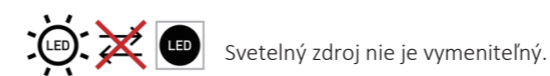

Svetelný zdroj nie je vymeniteľný.

SI:  
Izvor svetlobe:  
Vir svetlobe ni zamenljiv, ker je določen z zasnovno izdelka v okolici.  
Ta izdelek vsebuje svetlobni vir razreda energijske učinkovitosti <F>.

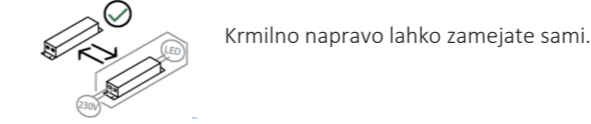

Krmilno napravo lahko zamejate sami.

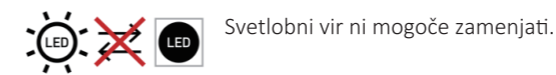

Svetlobni vir ni mogoče zamenjati.

ES:  
Fuente de luz:  
La fuente de luz no es sustituible porque está fija en el producto desde la construcción.  
Este producto contiene una fuente luminosa de la clase de eficiencia energética <F>.

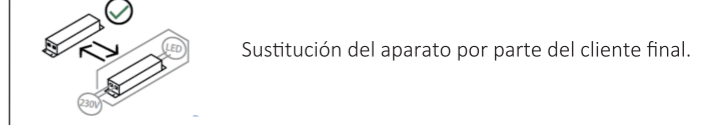

Sustitución del aparato por parte del cliente final.

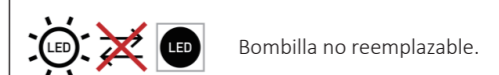

Bombilla no reemplazable.

EN:  
Energy efficiency class  
Light source:  
The light source is not interchangeable because it is determined by the surrounding product design.  
Notice for surveillance:  
In order to be able to access the light source, decorative elements must be removed; this may involve mechanical damage.  
This product contains a light source of energy efficiency class <F>.

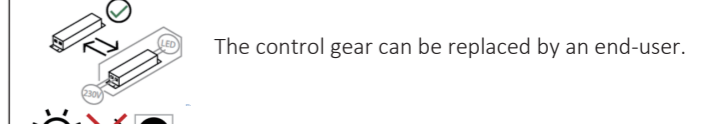

The control gear can be replaced by an end-user.

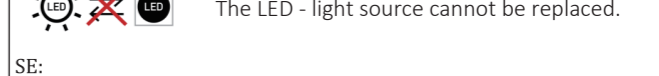

The LED - light source cannot be replaced.

SE:  
Ljuskälla:  
Ljuskällan är inte utbytbar, eftersom den på grund av konstruktionen är fast integrerad i den omgivande produkten.  
Denna produkt innehåller en ljuskälla med energieffektivitetsklass <F>.

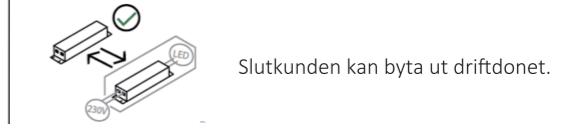

Slutkunden kan byta ut driftdonet.



kan inte bytas ut.

TR:  
Işık kaynağı:  
Konstrüksiyon gereği çevreyen ürün ile sabit bir şekilde bağlı olduğu için ışık kaynağı değiştirilemez.  
Bu ürün, <F> enerji sınıfından bir ışık kaynağına sahiptir.

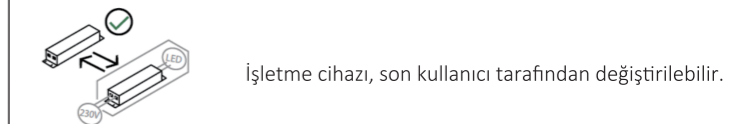

İşletme cihazı, son kullanıcı tarafından değiştirilebilir.



LED ışık kaynağı değiştirilemez.

UK:  
Джерело світла:  
Джерело світла не можна обміняти, оскільки воно міцно пов'язане з навколишнім виробом завдяки своїй конструкції.  
Цей виріб містить джерело світла класу енергоефективності <F>.

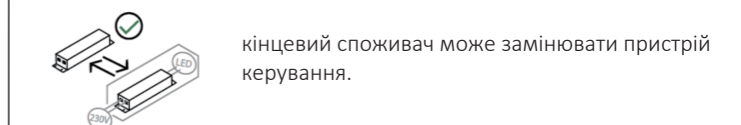

кінцевий споживач може замінювати пристрій керування.

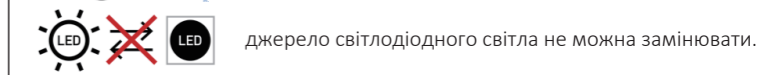

джерело світлодіодного світла не можна замінювати.